



# Pneumatic atomizing nozzles, Flat fan, pressure principle, external mixing Series 136.6



**Fine flat fan atomization with the aid of air or gas. Liquid pressure principle. External mixing of fluids.**

Applications:  
Web dampening, cooling, humidification of goods, atomization of viscous liquids.

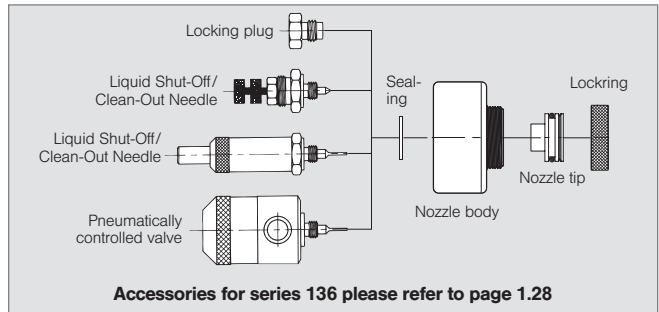
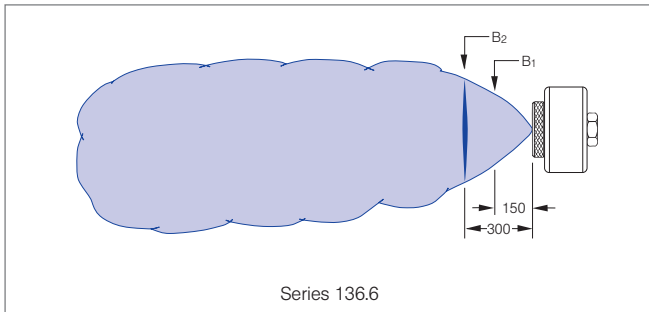
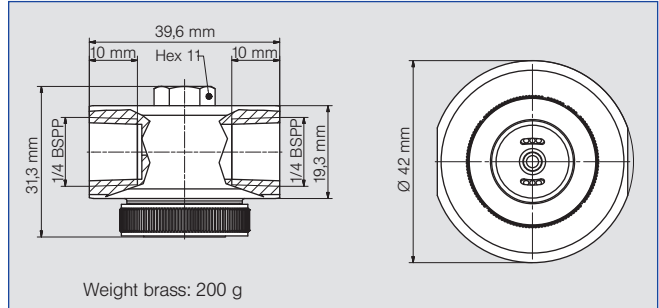

Spray angle	Ordering no.		E ∅ [mm]	Liquid pressure p [bar]												Spray dimensions							
	Type	Mat. no.		0.07				0.15				0.30				0.35				p Air [bar]	p Water [bar]	B1 [mm]	B2 [mm]
				1Y	35	p Air [bar]	V̇ Water [l/h]	V̇n Air [m³/h]	p Air [bar]	V̇ Water [l/h]	V̇n Air [m³/h]	p Air [bar]	V̇ Water [l/h]	V̇n Air [m³/h]	p Air [bar]	V̇ Water [l/h]	V̇n Air [m³/h]						
																		AISI 316L	Brass plated				
45°	136. 616. xx. A2	○	○	0.4	0.80	1.68	2.50	0.80	2.43	2.40	0.80	3.42	2.50	1.00	3.69	2.80	1.40	0.07	80	115			
					1.20	1.80	3.10	1.00	2.46	2.90	1.20	3.48	3.10	1.40	3.81	3.40	2.20	0.15	90	130			
					1.60	1.92	3.70	1.40	2.58	3.60	1.60	3.51	3.70	1.80	3.87	4.00	3.20	0.20	90	135			
					2.00	2.10	4.30	1.80	2.61	4.20	2.00	3.63	4.30	2.20	3.84	4.60	4.00	0.30	95	145			
					2.40	2.07	4.90	2.20	2.76	4.80	2.40	3.63	4.90	2.60	3.90	5.20	5.00	0.35	100	145			
					2.80	2.19	5.50	2.60	2.73	5.40	2.80	3.63	5.50	3.00	3.93	5.80							
					3.20	2.19	6.10	3.00	2.73	6.00	3.20	3.63	6.10	3.40	3.90	6.40							
					3.60	2.22	6.70	3.60	2.76	6.70	3.60	3.66	6.70	3.80	3.93	7.00							
					4.00	2.22	7.30	4.00	2.76	7.30	4.00	3.69	7.30	4.20	3.96	7.60							
					4.40	2.22	7.90	4.40	2.76	7.90	4.40	3.69	7.90	4.60	3.93	8.20							
					4.80	2.22	8.50	4.80	2.76	8.50	4.80	3.69	8.40	5.00	3.93	8.80							
					5.20	2.22	9.10	5.20	2.76	9.10	5.20	3.66	9.10	5.40	3.93	9.40							
					5.60	2.22	9.60	5.60	2.76	9.70	5.60	3.66	9.60	5.80	3.87	10.00							
					6.00	2.22	10.20	6.00	2.73	10.20	6.00	3.66	10.20	6.00	3.87	10.20							
	136. 635. xx. A2	○	○	0.5	0.80	2.37	2.50	0.80	3.45	2.40	0.80	4.80	2.40	1.00	5.34	2.80	1.40	0.07	85	120			
					1.20	2.61	3.10	1.20	3.54	3.10	1.20	5.10	3.10	1.40	5.37	3.40	2.20	0.15	95	130			
					1.60	2.85	3.70	1.60	3.66	3.70	1.60	5.01	3.70	1.80	5.46	4.00	3.20	0.20	95	135			
					2.00	3.03	4.30	2.00	3.72	4.30	2.10	5.10	4.30	2.20	5.46	4.60	4.00	0.30	100	140			
					2.40	3.12	4.90	2.40	3.90	4.90	2.40	5.13	4.90	2.60	5.58	5.20	5.00	0.35	100	145			
					2.80	3.15	5.50	2.80	3.87	5.50	2.80	5.16	5.50	3.00	5.58	5.80							
					3.20	3.21	6.10	3.20	3.96	6.10	3.20	5.22	6.10	3.40	5.58	6.40							
					3.60	3.18	6.70	3.60	3.96	6.70	3.60	5.25	6.70	3.80	5.58	7.00							
					4.00	3.21	7.30	4.00	3.96	7.20	4.00	5.22	7.30	4.20	5.58	7.60							
					4.40	3.21	7.90	4.40	3.96	7.90	4.40	5.22	7.90	4.60	5.58	8.10							
					4.80	3.21	8.40	4.80	3.96	8.40	4.80	5.22	8.40	5.00	5.58	8.70							
					5.20	3.21	9.00	5.20	3.96	9.00	5.20	5.22	9.00	5.40	5.58	9.30							
					5.60	3.12	9.60	5.60	3.90	9.60	5.60	5.22	9.60	5.80	5.58	9.90							
					6.00	3.18	10.20	6.00	3.84	10.20	6.00	5.16	10.20	6.00	5.58	10.20							





# Pneumatic atomizing nozzles, Flat fan, pressure principle, external mixing Series 136.6



Spray angle	Ordering no.		E ∅ [mm]	Liquid pressure p [bar]												Spray dimensions					
	Type	Mat. no.		0.07			0.15			0.30			0.35			p Air [bar]	p Water [bar]	B <sub>1</sub> [mm]	B <sub>2</sub> [mm]		
		1Y		35	p Air [bar]	V Water [l/h]	ṽ <sub>n</sub> Air [m <sup>3</sup> /h]	p Air [bar]	V Water [l/h]	ṽ <sub>n</sub> Air [m <sup>3</sup> /h]	p Air [bar]	V Water [l/h]	ṽ <sub>n</sub> Air [m <sup>3</sup> /h]	p Air [bar]	V Water [l/h]					ṽ <sub>n</sub> Air [m <sup>3</sup> /h]	
	AISI 316L	Brass plated																			
45°	136. 654. xx. A2	○	○	0.7	0.80	5.25	2.40	0.80	7.29	2.40	1.20	10.11	3.10	1.60	11.07	3.70	1.40	0.07	95	135	
					1.20	5.64	3.10	1.20	7.44	3.10	1.60	10.23	3.70	2.00	11.22	4.30	2.20	0.15	100	150	
					1.60	5.79	3.70	1.60	7.62	3.70	2.00	10.38	4.30	2.40	11.28	4.90	3.20	0.20	105	160	
					2.00	6.18	4.30	2.00	7.86	4.30	2.40	10.47	4.90	2.80	11.31	5.50	4.00	0.30	105	160	
					2.40	6.24	4.90	2.40	7.92	4.90	2.80	10.59	5.50	3.20	11.43	6.10	5.00	0.35	105	160	
					2.80	6.27	5.50	2.80	8.04	5.50	3.20	10.59	6.10	3.60	11.46	6.60					
					3.20	6.39	6.10	3.20	8.13	6.10	3.60	10.62	6.70	4.00	11.43	7.20					
					3.60	6.42	6.60	3.60	8.13	6.70	4.00	10.62	7.20	4.40	11.37	7.80					
					4.00	6.45	7.20	4.00	8.13	7.20	4.40	10.62	7.80	4.80	11.37	8.40					
					4.40	6.42	7.80	4.40	8.07	7.80	4.80	10.59	8.40	5.20	11.34	9.00					
					4.80	6.30	8.40	4.80	8.04	8.40	5.20	10.56	9.00	5.60	11.22	9.60					
					5.20	6.24	9.00	5.20	7.86	9.00	5.60	10.50	9.60	6.00	11.16	10.10					
					5.60	6.09	9.60	5.60	7.83	9.60	6.00	10.35	10.20	-	-	-					
6.00	5.85	10.20	6.00	7.59	10.20	-	-	-	-	-	-										
60°	136. 626. xx. A2	○	○	0.4	0.80	1.83	2.80	0.80	2.49	2.80	0.80	3.48	2.80	0.80	3.78	2.80	1.60	0.07	85	135	
					1.20	1.98	3.60	1.20	2.58	3.50	1.20	3.60	3.50	1.20	3.87	3.60	2.40	0.15	90	140	
					1.60	2.10	4.30	1.60	2.70	4.20	1.60	3.66	4.30	1.60	3.90	4.20	3.20	0.20	90	140	
					2.00	2.16	4.90	2.00	2.82	4.90	2.00	3.69	4.90	2.00	3.96	4.90	4.00	0.30	100	145	
					2.40	2.25	5.60	2.40	2.85	5.60	2.40	3.69	5.60	2.40	3.96	5.60	5.20	0.35	105	150	
					2.80	2.34	6.30	2.80	2.88	6.30	2.80	3.72	6.30	2.80	4.02	6.30					
					3.20	2.31	7.00	3.20	2.88	7.00	3.20	3.78	7.00	3.20	3.99	7.00					
					3.60	2.34	7.60	3.60	2.88	7.70	3.60	3.78	7.60	3.60	4.02	7.70					
					4.00	2.40	8.40	4.00	2.94	8.40	4.00	3.81	8.30	4.00	4.05	8.30					
					4.40	2.40	9.00	4.40	2.91	9.00	4.40	3.81	9.00	4.40	4.02	9.00					
	4.80	2.40	9.70	4.80	2.97	9.70	4.80	3.81	9.70	4.80	4.08	9.70									
	5.20	2.43	10.40	5.20	2.97	10.40	5.20	3.81	10.40	5.20	4.05	10.40									
	5.60	2.43	11.20	5.60	2.97	11.10	5.60	3.81	11.10	5.60	4.05	11.00									
	6.00	2.43	11.80	6.00	2.97	11.80	6.00	3.81	11.80	6.00	4.05	11.80									
	136. 645. xx. A2	○	○	0.5	0.80	2.73	2.80	0.80	3.69	2.80	1.00	5.16	3.20	1.00	5.55	3.10	1.60	0.07	100	140	
					1.20	2.82	3.50	1.20	3.87	3.50	1.40	5.31	3.90	1.40	5.64	3.90	2.40	0.15	110	150	
					1.60	3.09	4.20	1.60	3.99	4.20	1.80	5.37	4.60	1.80	5.67	4.60	3.20	0.20	115	155	
					2.00	3.27	4.90	2.00	4.11	4.90	2.20	5.37	5.20	2.20	5.76	5.20	4.00	0.30	125	160	
					2.40	3.36	5.60	2.40	4.17	5.60	2.60	5.43	5.90	2.60	5.82	5.90	5.20	0.35	130	165	
					2.80	3.39	6.20	2.80	4.20	6.30	3.00	5.49	6.60	3.00	5.82	6.60					
3.20					3.45	7.00	3.20	4.26	7.00	3.40	5.49	7.20	3.40	5.88	7.30						
3.60					3.48	7.60	3.60	4.29	7.60	3.80	5.55	8.00	3.80	5.88	8.00						
4.00					3.51	8.30	4.00	4.32	8.30	4.20	5.55	8.60	4.20	5.88	8.70						
4.40					3.54	9.00	4.40	4.35	9.00	4.60	5.58	9.30	4.60	5.94	9.30						
4.80	3.57	9.70	4.80	4.38	9.70	5.00	5.55	10.00	5.00	5.94	10.10										
5.20	3.57	10.40	5.20	4.35	10.40	5.40	5.61	10.70	5.40	5.94	10.70										
5.60	3.60	11.00	5.60	4.35	11.10	5.80	5.61	11.40	5.80	5.94	11.40										
6.00	3.60	11.70	6.00	4.38	11.70	6.00	5.61	11.80	6.00	5.97	11.80										

E = narrowest free cross section (water)

Continued on next page.

**Example**    **Type**            + **Material no. (xx)** = **Ordering no.**  
**for ordering:**    **136. 654 xx. A2** + **1Y**                                = **136. 654. 1Y. A2**



# Pneumatic atomizing nozzles, Flat fan, pressure principle, external mixing Series 136.6



Spray angle	Ordering no.		E ∅ [mm]	Liquid pressure p [bar]												Spray dimensions					
	Type	Mat. no.		0.07			0.15			0.30			0.35			p Air [bar]	p Water [bar]	B <sub>1</sub> [mm]	B <sub>2</sub> [mm]		
				p Air [bar]	V Water [l/h]	V <sub>n</sub> Air [m <sup>3</sup> /h]	p Air [bar]	V Water [l/h]	V <sub>n</sub> Air [m <sup>3</sup> /h]	p Air [bar]	V Water [l/h]	V <sub>n</sub> Air [m <sup>3</sup> /h]	p Air [bar]	V Water [l/h]	V <sub>n</sub> Air [m <sup>3</sup> /h]						
	1Y	35																			
		AISI 316L	Brass plated																		
60°	136. 664. xx. A2	○	○	0.7	0.80	5.46	2.80	1.00	7.68	3.20	1.00	10.50	3.20	1.00	11.28	3.20	1.60	0.07	110	140	
					1.20	5.91	3.50	1.40	7.95	3.90	1.40	10.71	3.90	1.40	11.52	3.90	2.40	0.15	130	160	
					1.60	6.15	4.20	1.80	8.13	4.60	1.80	10.83	4.60	1.80	11.58	4.50	3.20	0.20	140	170	
					2.00	6.42	4.90	2.20	8.34	5.30	2.20	11.01	5.30	2.20	11.70	5.20	4.00	0.30	150	180	
					2.40	6.63	5.60	2.60	8.46	5.90	2.60	11.07	5.90	2.60	11.79	5.90	5.20	0.35	155	200	
					2.80	6.75	6.30	3.00	8.58	6.60	3.00	11.16	6.60	3.00	11.88	6.60					
					3.20	6.93	6.90	3.40	8.67	7.30	3.40	11.19	7.30	3.40	11.94	7.30					
					3.60	6.99	7.60	3.80	8.73	8.00	3.80	11.25	8.00	3.80	12.00	8.00					
					4.00	7.05	8.30	4.20	8.76	8.70	4.20	11.28	8.60	4.20	12.03	8.70					
					4.40	7.11	9.00	4.60	8.82	9.30	4.60	11.34	9.40	4.60	12.06	9.40					
					4.80	7.11	9.70	5.00	8.82	10.10	5.00	11.37	10.00	5.00	12.06	10.10					
					5.20	7.17	10.40	5.40	8.82	10.70	5.40	11.37	10.70	5.40	12.09	10.70					
					5.60	7.11	11.10	5.80	8.85	11.40	5.80	11.40	11.40	5.80	12.12	11.40					
					6.00	7.20	11.80	6.00	8.85	11.80	6.00	11.40	11.70	6.00	12.15	11.80					
						136. 673. xx. A2	○	○	1.0	0.60	13.89	5.60	1.00	18.51	7.60	1.60	24.81	10.20	2.00	26.61	11.80
	1.00	14.28	7.60	1.40	18.51					9.30	2.00	24.66	11.70	2.40	26.31	13.50	2.40	0.15	120	160	
	1.40	14.28	9.40	1.80	18.33					11.00	2.40	24.42	13.30	2.80	25.65	15.10	3.20	0.20	120	160	
	1.80	14.10	11.00	2.20	17.91					12.70	2.80	23.52	15.10	3.20	24.57	16.60	4.00	0.30	120	165	
	2.20	13.68	12.60	2.60	17.37					14.20	3.20	22.47	16.60	3.60	23.28	18.30	5.20	0.35	120	170	
	2.60	13.62	14.20	3.00	16.65					15.90	3.60	21.30	18.40	4.00	21.93	19.90					
	3.00	13.29	18.90	3.40	15.93					17.30	4.00	20.10	19.80	4.40	20.34	21.50					
	3.40	12.87	17.40	3.80	15.06					19.00	4.40	18.78	21.50	4.80	19.20	23.10					
	3.80	12.57	19.10	4.20	14.58					20.80	4.80	17.52	23.20	5.20	18.06	24.70					
	4.20	12.18	20.80	4.60	13.83					22.30	5.20	16.71	24.80	5.60	17.01	26.30					
	4.60	11.79	22.40	5.00	13.08					24.00	5.60	15.63	26.40	6.00	15.87	28.00					
	5.00	10.95	24.00	5.40	12.30					25.60	5.80	15.12	27.30	-	-	-					
	5.40	10.44	25.60	5.80	11.52					27.20	6.00	14.76	28.00	-	-	-					
	5.80	9.57	27.20	6.00	11.04					28.10	-	-	-	-	-	-					
	6.00	8.97	28.10	-	-					-	-	-	-	-	-	-					
		136. 682. xx. A2	○	○	1.5	1.00	22.41	7.50	1.40	28.95	9.30	1.80	41.22	11.10	2.00	44.04	11.80	1.60	0.07	110	155
1.40	20.19					9.30	1.80	26.07	10.90	2.20	34.92	12.60	2.40	39.09	13.40	2.40	0.15	120	155		
1.80	18.75					11.00	2.20	23.94	12.50	2.60	33.18	14.20	2.80	35.16	15.10	3.20	0.20	120	160		
2.20	17.88					12.50	2.60	22.23	14.30	3.00	30.45	15.90	3.20	32.22	16.70	4.00	0.30	120	165		
2.60	17.10					14.20	3.00	21.12	15.90	3.40	28.29	17.50	3.60	30.18	18.30	5.20	0.35	120	175		
3.00	16.47					15.90	3.40	20.10	17.50	3.80	26.64	19.10	4.00	28.32	19.90						
3.40	16.08					17.50	3.80	19.44	19.10	4.20	25.35	20.70	4.40	26.94	21.50						
3.80	15.90					19.10	4.20	18.99	20.70	4.60	24.24	22.30	4.80	25.59	23.10						
4.20	15.90					20.70	4.60	18.45	22.30	5.00	23.13	24.00	5.20	24.36	24.80						
4.60	15.81					22.30	5.00	18.18	24.00	5.40	22.14	25.50	5.60	23.28	26.40						
5.00	15.21					23.90	5.40	17.25	25.40	5.80	21.12	27.20	6.00	22.17	28.00						
5.40	13.92					25.50	5.80	15.72	27.20	6.00	20.67	28.00	-	-	-						
5.80	12.09					27.20	6.00	14.91	28.00	-	-	-	-	-	-						
6.00	11.07					28.00	-	-	-	-	-	-	-	-	-						

E = narrowest free cross section (water)

Continued on next page.

**Example**    **Type**    + **Material no. (xx)**    = **Ordering no.**  
**for ordering:**    136. 664 xx. A2    +    1Y    =    136. 664. 1Y. A2





# Pneumatic atomizing nozzles, Flat fan, pressure principle, external mixing Series 136.6



Spray angle	Ordering no.		E Ø [mm]	Liquid pressure p [bar]												Spray dimensions					
	Type	Mat. no.		0.07			0.15			0.30			0.35			p Air [bar]	p Water [bar]	B <sub>1</sub> [mm]	B <sub>2</sub> [mm]		
				1Y	35	p Air [bar]	V Water [l/h]	V <sub>n</sub> Air [m <sup>3</sup> /h]	p Air [bar]	V Water [l/h]	V <sub>n</sub> Air [m <sup>3</sup> /h]	p Air [bar]	V Water [l/h]	V <sub>n</sub> Air [m <sup>3</sup> /h]	p Air [bar]					V Water [l/h]	V <sub>n</sub> Air [m <sup>3</sup> /h]
	AISI 316L	Brass plated																			
60°	136. 691. xx. A2	○	○	2.5	1.40	52.00	13.80	2.00	67.30	17.50	2.60	92.30	21.20	2.60	102.10	21.20	1.60	0.07	150	200	
					1.80	50.00	16.30	2.40	64.60	20.10	3.00	87.70	23.60	3.00	97.20	23.70	2.40	0.15	160	205	
					2.20	48.60	18.80	2.80	62.00	22.50	3.40	84.30	26.00	3.40	92.50	26.10	3.20	0.20	160	205	
					2.60	47.50	21.30	3.20	60.40	24.90	3.80	80.70	28.50	3.80	88.40	28.50	4.00	0.30	160	210	
					3.00	46.50	23.70	3.60	58.00	27.30	4.20	77.00	30.90	4.20	85.20	31.00	5.20	0.35	150	210	
					3.40	45.40	26.10	4.00	56.20	29.80	4.60	74.40	33.40	4.60	81.30	33.40					
					3.80	44.40	28.60	4.40	54.20	32.10	5.00	71.10	35.90	5.00	78.20	35.80					
					4.20	42.90	31.00	4.80	52.40	34.70	5.40	68.10	38.30	5.40	74.30	38.20					
					4.60	41.50	33.40	5.20	49.90	37.10	5.80	64.30	40.80	5.80	71.10	40.70					
					5.00	39.90	35.80	5.60	48.10	39.50	6.00	63.20	42.00	6.00	68.90	41.90					
					5.40	38.90	38.30	6.00	46.40	42.00	-	-	-	-	-	-	-				
					5.60	38.50	39.40	-	-	-	-	-	-	-	-	-	-				

E = narrowest free cross section (water)

**Operational information:**  
Liquid flow of pneumatic atomizing nozzles with external mixing can be turned down to 0 with air pressure remaining constant.

**Example for ordering:** Type 136. 691 xx. A2 + Material no. (xx) 1Y = Ordering no. 136. 691. 1Y. A2

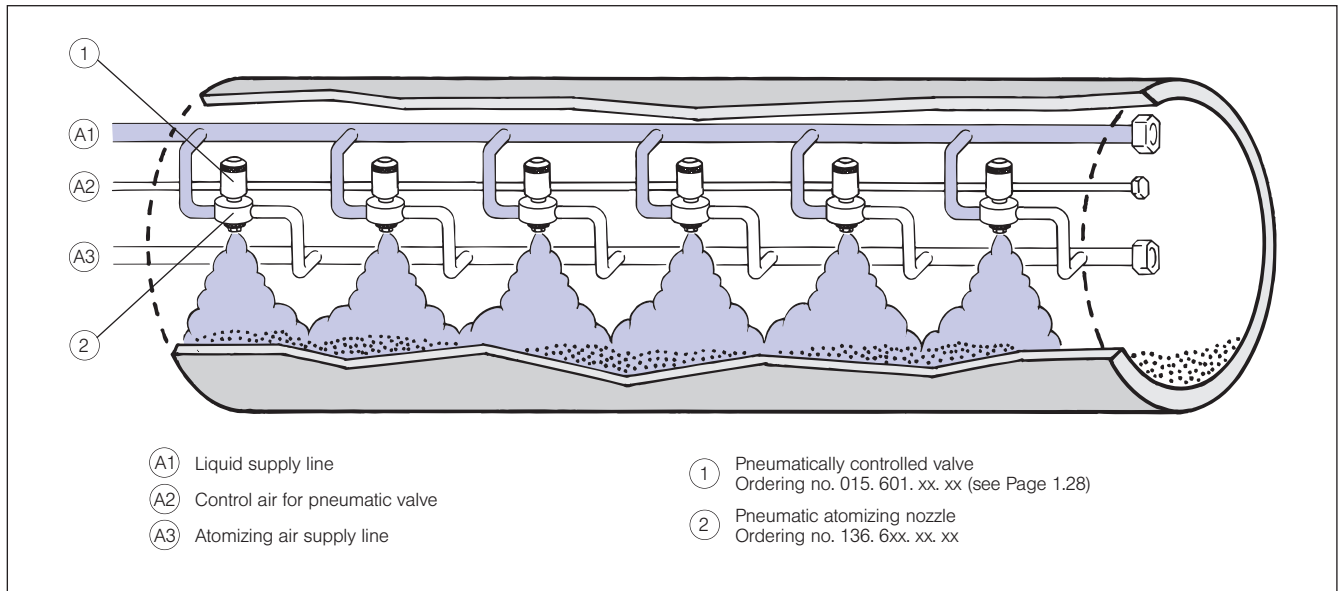

Cereal dampening in a mixing drum