

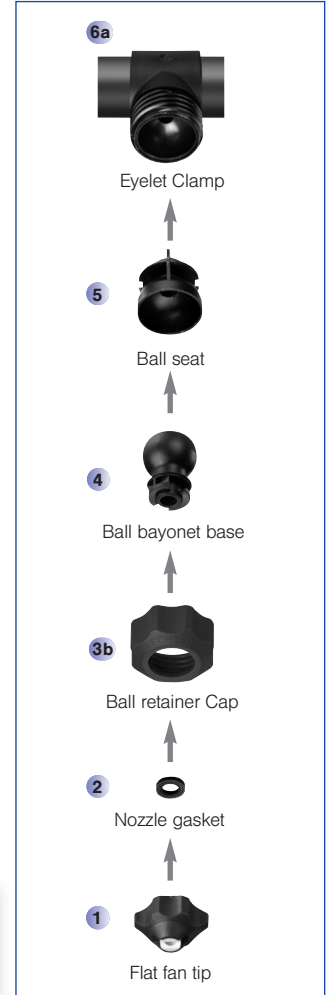

Maintaining of the adjusted spray direction by the »memory effect«. Very easy handling without the need for special tools. Especially pressure resistant pipe connector.

Application:
Degreasing, phosphating in surface treatment, cleaning.

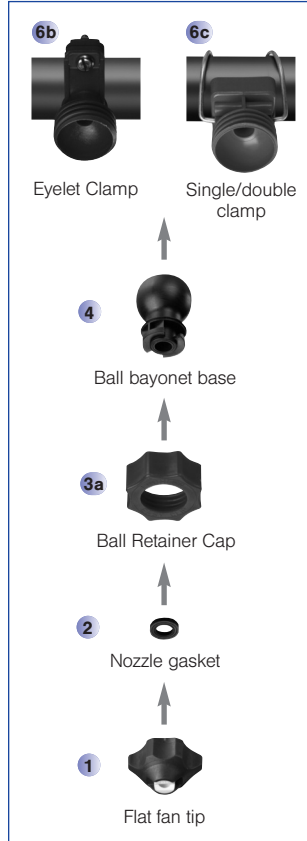
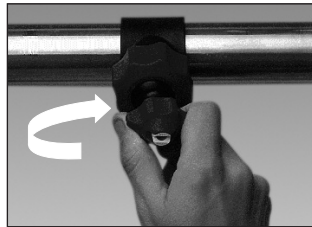
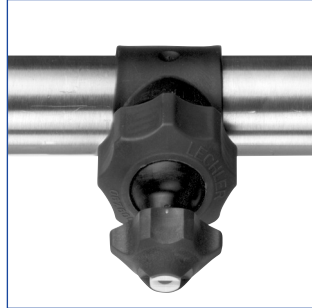

Type	∠	Ordering no.	Material				E Ø [mm]	Flow rate [l/min] bei p [bar]					Weight [g]			
			Housing: PP Insert: 303 SS	Housing: PP Insert: 316 L	Housing: PP Insert: ceramic	Polypropylene (PP)		1.0	1.5	2.0	2.5	5.0	PP/ AISI 316TI	PP/ AISI 316L	PP/Ceramic	PP
1 Flat fan nozzle	30°	676. 642. xx. 40	○	○	-	-	1.6	2.83	3.46	4.00	4.47	6.33	15	15	-	-
	30°	676. 722. xx. 40	○	○	-	-	2.1	4.46	5.46	6.30	7.04	9.96	15	15	-	-
	30°	676. 762. xx. 40	○	○	-	-	2.3	5.66	6.93	8.00	8.94	12.65	15	15	-	-
	30°	676. 802. xx. 40	○	○	-	-	2.6	7.07	8.66	10.00	11.18	15.81	15	15	-	-
	30°	676. 842. xx. 40	○	○	-	-	3.0	8.84	10.82	12.50	13.97	19.76	15	15	-	-
	30°	676. 882. xx. 40	○	○	-	-	3.4	11.31	13.86	16.00	17.89	25.30	15	15	10	8
	30°	676. 922. xx. 40	○	○	-	-	4.1	14.14	17.32	20.00	22.36	31.62	15	15	10	8
1 Flat fan nozzle	30°	676. 962. xx. 40	○	○	-	-	4.2	17.68	21.65	25.00	27.95	39.53	15	15	10	8
	30°	677. 002. xx. 40	○	-	-	-	4.7	22.27	27.28	31.50	35.22	49.81	15	-	-	-
	60°	676. 644. xx. 40	○	○	-	-	1.6	2.83	3.46	4.00	4.47	6.33	15	15	-	-
	60°	676. 724. xx. 40	○	○	-	-	2.1	4.46	5.46	6.30	7.04	9.96	15	15	-	-
	60°	676. 764. xx. 40	○	○	-	-	2.3	5.66	6.93	8.00	8.94	12.65	15	15	-	-
	60°	676. 804. xx. 40	○	○	-	-	2.6	7.07	8.66	10.00	11.18	15.81	15	15	-	-
	60°	676. 844. xx. 40	○	○	-	-	3.0	8.84	10.82	12.50	13.97	19.76	15	15	-	-
	60°	676. 884. xx. 40	○	○	○	○	3.4	11.31	13.86	16.00	17.89	25.30	15	15	10	8
	60°	676. 924. xx. 40	○	○	○	○	4.1	14.14	17.32	20.00	22.36	31.62	15	15	10	8
	60°	676. 964. xx. 40	○	○	○	○	4.2	17.68	21.65	25.00	27.95	39.53	15	15	10	8
60°	677. 004. xx. 40	○	○	○	○	4.7	22.27	27.28	31.50	35.22	49.81	15	15	10	8	
1 Flat fan nozzle	60°	677. 044. xx. 40	○	○	-	-	5.5	28.28	34.64	40.00	44.72	63.25	15	15	-	-
	60°	677. 084. xx. 40	○	○	-	-	6.2	35.36	43.30	50.00	55.90	79.06	15	15	-	-

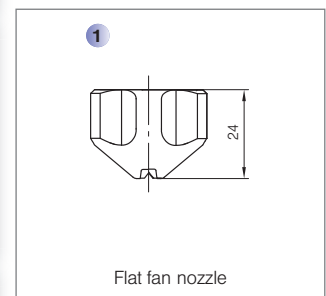

Continued on next page.

Conversion formula for the above series: $\dot{V}_2 = \dot{V}_1 * \sqrt{\frac{p_2}{p_1}}$





Type	α	Ordering no.	Material				E Ø [mm]	Flow rate [l/min] at p [bar]					Weight [g]				
			8F Housing: PP Insert: AISI 303	8R Housing: PP Insert: AISI 316L	E8 Housing: PP Insert: ceramic	53 Polypropylene (PP)		1.0	1.5	2.0	2.5	5.0	PP/ AISI 316Ti	PP/ AISI 316L	PP/Ceramic	PP	
1 Flat fan nozzle	90°	676. 646. xx. 40	○	○	-	-	1.6	2.83	3.46	4.00	4.47	6.33	15	15	-	-	-
	90°	676. 726. xx. 40	○	○	-	-	2.1	4.46	5.46	6.30	7.04	9.96	15	15	-	-	-
	90°	676. 766. xx. 40	○	○	-	-	2.3	5.66	6.93	8.00	8.94	12.65	15	15	-	-	-
	90°	676. 806. xx. 40	○	○	-	-	2.6	7.07	8.66	10.00	11.18	15.81	15	15	-	-	-
	90°	676. 846. xx. 40	○	○	-	-	3.0	8.84	10.82	12.50	13.97	19.76	15	15	-	-	-
	90°	676. 886. xx. 40	○	○	-	-	3.4	11.31	13.86	16.00	17.89	25.30	15	15	-	-	-
	90°	676. 926. xx. 40	○	○	-	-	4.1	14.14	17.32	20.00	22.36	31.62	15	15	-	-	-
1 Flat fan nozzle	90°	676. 966. xx. 40	○	○	-	-	4.2	17.68	21.65	25.00	27.95	39.53	15	15	-	-	-
	120°	676. 647. xx. 40	○	○	-	-	1.6	2.83	3.46	4.00	4.47	6.33	15	15	-	-	-
	120°	676. 727. xx. 40	○	○	-	-	2.1	4.46	5.46	6.30	7.04	9.96	15	15	-	-	-
	120°	676. 767. xx. 40	○	○	-	-	2.3	5.66	6.93	8.00	8.94	12.65	15	15	-	-	-
	120°	676. 807. xx. 40	○	○	-	-	2.6	7.07	8.66	10.00	11.18	15.81	15	15	-	-	-
	120°	676. 847. xx. 40	○	○	-	-	3.0	8.84	10.82	12.50	13.97	19.76	15	15	-	-	-
	120°	676. 887. xx. 40	○	○	-	-	3.4	11.31	13.86	16.00	17.89	25.30	15	15	-	-	-
120°	676. 927. xx. 40	○	○	-	-	4.1	14.14	17.32	20.00	22.36	31.62	15	15	-	-	-	

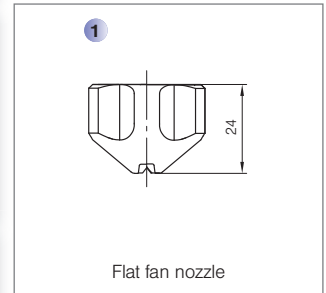

	α	η	Ordering no.	Material		E Ø [mm]	Flow rate [l/min] at p [bar]					Weight [g]	
				8R Housing: PP Insert: AISI 316L	5E PVDF		1.0	1.5	2.0	2.5	5.0	PP/ AISI 316L	PVDF
1a Tongue type nozzle	45°	35°	676. 803. XX. 41	○	-	3.4	7.07	8.66	10.00	11.18	15.81	25	-
	60°	35°	676. 874. XX. 41	○	-	4.2	10.61	12.99	15.00	16.77	23.72	25	-
	60°	35°	676. 924. XX. 41	○	-	4.7	14.14	17.32	20.00	22.36	31.62	25	-
	70°	40°	677. 005. XX. 41	○	○	6.0	22.27	27.28	31.50	35.22	49.81	25	11

E = narrowest free cross section

Example Type + Material-no. = Ordering no.
for Ordering: 676. 646. xx. 40 + 8R = 676. 646. 8R. 40

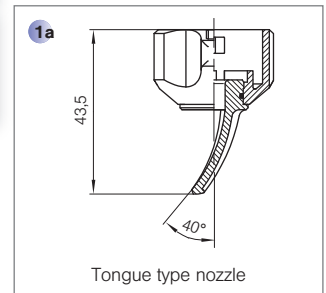



Type	Ordering no.	Material				Bore-Ø B	For pipe-Ø	Weight [g]	
		53 Polypropylene (PP)	6M PP reinforced	6C EPDM	7A Viton			PP	EPDM/Viton
2 Nozzle gasket	095.015.xx.05.65.0	-	-	○	○			-	1
3a Ball retainer cap	092.080.xx.00.02	○	-	-	-			18	-
3b Ball retainer cap	067.600.xx.40	○	-	-	-			18	-
4 Ball bayonet base	067.630.xx.40	○	-	-	-			12	-
5 Ball seat for Ball retainer cap no. 067.631.xx.40.00.0	067.631.xx.40.22.0	-	○	-	-	13.8 mm	1 1/4" (40.0-43.0 mm)	9	-
	067.631.xx.40.02.0	-	○	-	-	16.0 mm	1 1/4" (40.0-43.0 mm)	11	-
	067.631.xx.40.12.0	-	○	-	-	19.8 mm	1 1/4" (40.0-43.0 mm)	13	-
Ball seat for Ball retainer cap no. 067.631.xx.50.00.0	067.631.xx.50.22.0	-	○	-	-	13.8 mm	1 1/2" (46.0-49.0 mm)	9	-
	067.631.xx.50.02.0	-	○	-	-	16.0 mm	1 1/2" (46.0-49.0 mm)	11	-
	067.631.xx.50.12.0	-	○	-	-	19.8 mm	1 1/2" (46.0-49.0 mm)	13	-
6a Eyelet clamp	067.631.xx.40.00.0	○	-	-	-	-	1 1/4" (40.0-43.0 mm)	31	-
	067.631.xx.50.00.0	○	-	-	-	-	1 1/2" (46.0-49.0 mm)	33	-
6b Eyelet clamp	090.023.xx.44.10.0	○	-	-	-	13.8 mm	1" (32.0-34.5 mm)	48	-
	090.023.xx.43.10.0	○	-	-	-	16.0 mm	1" (32.0-34.5 mm)	48	-
	090.033.xx.44.10.0	○	-	-	-	13.8 mm	1 1/4" (40.0-43.0 mm)	50	-
	090.033.xx.43.10.0	○	-	-	-	16.0 mm	1 1/4" (40.0-43.0 mm)	50	-
	090.033.xx.40.10.0	○	-	-	-	20.0 mm	1 1/4" (40.0-43.0 mm)	50	-
	090.043.xx.44.10.0	○	-	-	-	13.8 mm	1 1/2" (46.0-49.0 mm)	52	-
6c Single clamp	092.081.xx.00	○	-	-	-	16.0 mm	1 1/4" (40.0-43.0 mm)	38	-
	092.082.xx.00	○	-	-	-	16.0 mm	1 1/2" (46.0-49.0 mm)	40	-
	092.083.xx.00	○	-	-	-	16.0 mm	2" (58.0-62.0 mm)	42	-

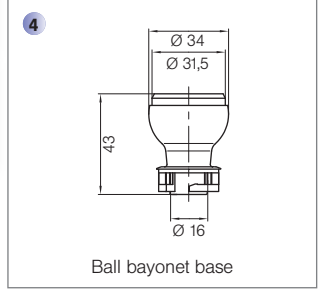
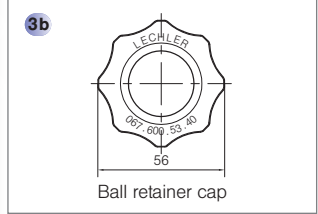
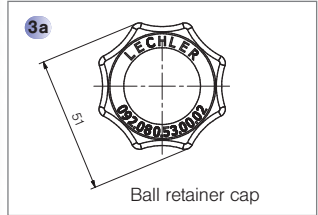
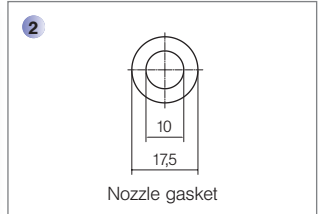

* other bore-Ø on request
E = narrowest free cross section

Example Type + Material-no. = Ordering no.
for ordering: 095.015.xx.05.065.0 + 53 = 095.015.53.05.065.0

