

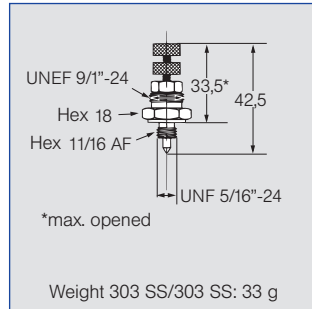

Accessories for pneumatic atomizing nozzles Series 136.1 - 136.6

Regulating device and shutting-off needle:



Ordering no.		For nozzles of the series 136
Type	Mat. no.	
	16	303 SS
015. 600	●	

Pneumatically controlled valve. Opening pressure 2.1 bar, max. 180 cycles/min.

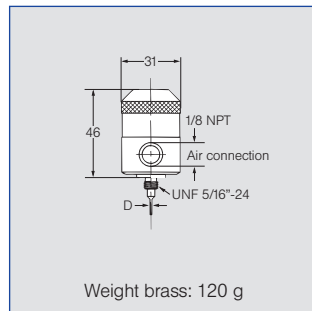

Ordering no.		For nozzles	Needle diameter D [mm]
Type	Mat. no.		
	16 35		
	303 SS Brass plated		
013. 601. xx. 10	● ●	136. xx1	2.1
013. 602. xx. 10	● ●	136. xx2	1.2
013. 603. xx. 10	● ●	136. xx3	0.8
013. 604. xx. 10	● ●	136. xx4	0.6
013. 605. xx. 10	● ●	136. xx5	0.4
013. 606. xx. 10	● ●	136. xx6	0.3

Quick-cleaning device

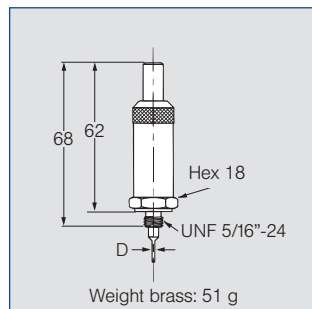

Ordering no.		For nozzles	Needle diameter D [mm]
Type	Mat. no.		
	16 35		
	303 SS Brass plated		
013. 601. xx. 20	● ●	136. xx1	2.1
013. 602. xx. 20	● ●	136. xx2	1.2
013. 603. xx. 20	● ●	136. xx3	0.8
013. 604. xx. 20	● ●	136. xx4	0.6
013. 605. xx. 20	● ●	136. xx5	0.4
013. 606. xx. 20	● ●	136. xx6	0.3

Regulating device with quick-cleaning needle

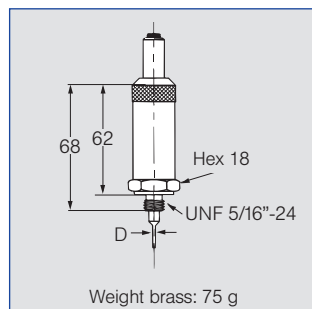
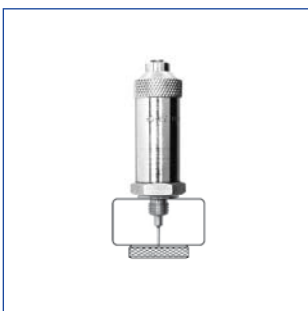

Ordering no.		For nozzles	Needle diameter D [mm]
Type	Mat. no.		
	16 35		
	303 SS Brass plated		
013. 601. xx. 30	● ●	136. xx1	2.1
013. 602. xx. 30	● ●	136. xx2	1.2
013. 603. xx. 30	● ●	136. xx3	0.8
013. 604. xx. 30	● ●	136. xx4	0.6
013. 605. xx. 30	● ●	136. xx5	0.4
013. 606. xx. 30	● ●	136. xx6	0.3